

Safety Warning

NOTE: If you are new to electrical work, or if it's been awhile, please visit www.nubryte.com/support to read the full installation instructions in our User Guide before proceeding.

CAUTION: Use only with permanently-installed lighting fixtures. To avoid overheating and possible damage to other equipment, do not use to control power outlets (including switch-controlled lamps), fluorescent lighting fixtures, motor-driven appliances (e.g. ceiling fans with lights), or transformer-supplied appliances.

Installations should be performed in accordance with all national and local electrical codes. This product should not be installed on circuits where multi-way switches exist (two or more switches controlling the same light). NuBryte Touchpoint requires a neutral wire and cannot be installed without one. Consult NuBryte support or a licensed electrician or if your home wiring is aluminum.

If you are unsure or have questions about the installation, please visit support at www.nubryte.com/support or seek the advice of a qualified electrician.

If you notice anything unusual about the electric supply to your light switch, such as loose wires, exposed cabling, burn marks, holes in the insulating materials or damage to the electric wires, STOP IMMEDIATELY and seek the advice from a licensed electrician.

Full Instructions, Safety Guidance, and Support Resources are available in our NuBryte Touchpoint User Guide at www.nubryte.com/support

Installation Requirements

- Wireless WiFi Router (not included)
- Neutral Wire in existing light switch
- Light controlled by one switch location, ie single pole switch - (Not to be installed with a 3-way or multi-way switches)
- Smart phone running on the latest software version (support from iOS 7.1 and up)

This Package Includes

- 1 NuBryte Touchpoint Display Unit
- 1 NuBryte Touchpoint Base Unit
- 4 Wire Connectors
- 1 Set of Wire Labels
- 2 Screws
- 1 Quick Start Guide
- 1 Window Decal

NOTE: Double Gang units contain an additional 4 Wire Connectors, 2 Screws and 1 Set of Wire Labels.

Tools Needed

- Screwdrivers: Flathead and Phillips
- Pliers
- Wire stripper
- Non-contact voltage detector
- Wire cutter (optional)
- Electrical tape (optional)

Visit www.nubryte.com/support to read full installation instructions in our User Guide before proceeding.

Risk of Electrical Shock. Please read the Quick Start Guide and Safety Warnings in full before beginning installation

1 Turn OFF Power

Turn power OFF to the switch you're replacing, at the main power source.

CAUTION: Use a non-contact voltage detector to ensure that there is no power to any wires in the switch box before proceeding.

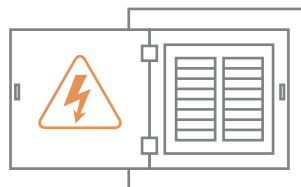

2 Remove Your Old Switch

Attach the provided labels to the corresponding wires to help you remember which were wired together.

- Ground (≡) Green,** Green-Yellow or Bare. Optional, not always present.
- Live/ Hot (⚡) and Load (💡)** Usually Black or Red. Required, always present.
- Neutral (N) White.** Required, not always present.

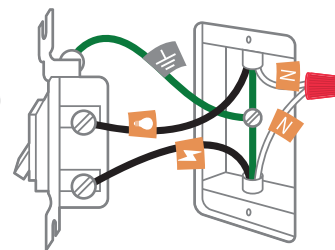

STOP if you do not have a Neutral Wire or find your home has aluminum wiring and contact NuBryte support or consult a licensed electrician.

3a Single Gang Wiring

Wire the NuBryte Base Unit, using the labels to identify the correct wires to twist together with enclosed wire connectors.

- **Load to Load** from lighting fixture
- **Live to Live** from main breaker
- **All Neutral** wires together
- **All Ground** wires with wire from box

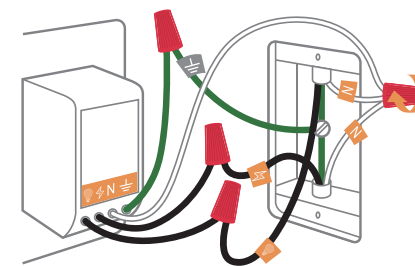

3b Double Gang Wiring

Follow the wiring instructions below when wiring a double gang NuBryte base unit. Remember to take note of the wiring labels you applied when matching the wires.

- **Load to Load** from lighting fixture to each dimmer
- **Live to Live** from main breaker for each dimmer
- **All Neutral** wires together
- **All Ground** wires with wire from box

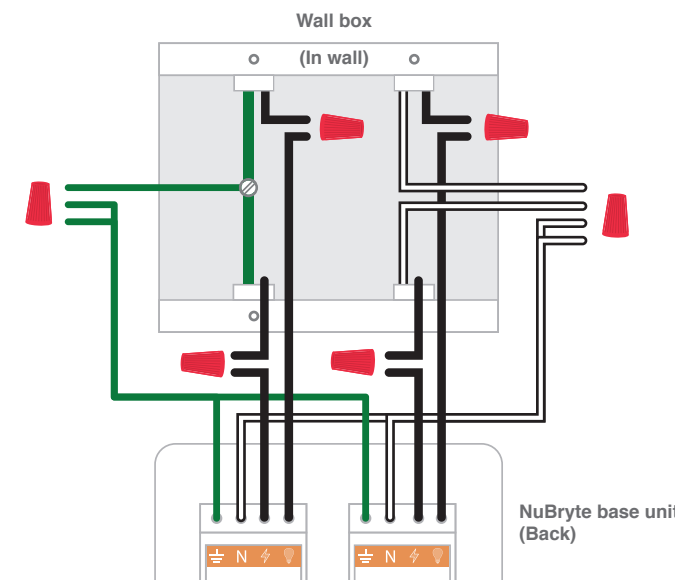

Continued



4 Attach the Base Unit

Position and screw the NuBryte Base Unit into your home's existing switch box, using the provided screws. There are two screws for single gang and four for double. Make sure all of the wires and wire connectors are neatly enclosed behind the Base Unit.

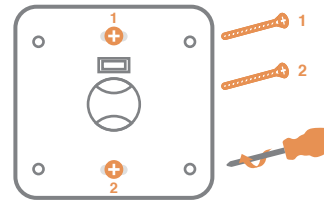

5 Turn ON Power

Turn power ON at the main power source and test the light switch. If the lights do not turn on it may mean you have wired the Live and Load wires incorrectly. Turn the mains power off at the source, go back to Step 3 and swap the wires connected to the Live and Load wires before continuing.

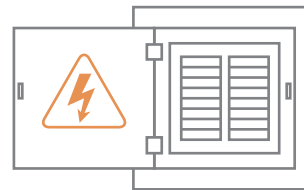

6 Attach the Display Unit

Align the four pegs in each corner on the back of the LCD Display Unit with the corresponding holes on the Base Unit. Once aligned, press the Display Unit on to the Base Unit until you hear a click.

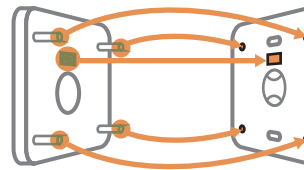

7 NuBryte Touchpoint Setup Wizard

Follow the setup wizard on the device to get started with the NuBryte Touchpoint.

8 Download Smartphone App

Download the NuBryte App from the relevant store and install on your smartphone.



9 Register Your NuBryte Account

Open the App and sign up for a NuBryte account. During this process, you can invite your household family members by email so they too can download the app, log in securely, and use NuBryte.

10 More Resources on the Web

Visit www.nubryte.com to learn more about NuBryte and its features, review FAQ and troubleshooting support resources, and join the conversation with other NuBryte users.

LUCIS Technologies warrants NuBryte products purchased and installed in the U.S. / Canada for one year. Full details can be found at www.nubryte.com.

NuBryte

Quick Start Guide